

# PHARMALINE N and X

SMOOTHBORE, FLEXIBLE PTFE HOSE



- HYGIENIC

- FLEXIBLE

- SELF CLEANING

- KINK RESISTANT

- CHEMICAL RESISTANT

## **INTRODUCTION TO PHARMALINE N**

- PTFE - The Optimum Choice For Hose Linings **Page 3**
- Pharmaline N and X - The New Product Designs from Aflex Hose **Page 4**
- Pharmaline N and X Hose Descriptions **Page 5**
- Pharmaline N and X Specifications & Properties **Page 6**
- How to Order Pharmaline N and X Hose Assemblies **Page 7**
- Part Numbers for Pharmaline N and X Hose Assemblies **Page 8**

## **HOSE**

- Pharmaline N and X, GP and AS PTFE Liners **Page 9**

## **FLANGE FITTINGS**

- Swivel Flange Fittings **Page 10**

## **CAM AND GROOVE FITTINGS (CAMLOCKS)**

- Female and Male Cam & Groove Fittings **Page 11**

## **SANITARY (TRICLOVER) FITTINGS**

- Sanitary and Mini-Sanitary Triclover Fittings **Page 12**
- 90° Elbow Sanitary Triclover Fittings **Page 13**

## **NPT & BSPT FITTINGS**

- NPT & BSPT Fixed Male Fittings and NPT Fixed Female Fittings **Page 14**
- BSP 60° Cone Seat Female Unions and BSP Flat Seat Lug Nut Female Fittings **Page 15**

## **JIC FITTINGS**

- 37° JIC Female Fittings & NPT Male & Female Unions **Page 16**

## **TUBE ADAPTOR FITTINGS**

- Tube Adaptor (Grooved Standpipe) Fittings **Page 17**

## **DIP PIPES**

**Page 18**

## **PHARMALINE N or X HOSES ASSEMBLED WITH DIRECT CRIMP (DC) END FITTINGS**

**Page 19**

## **PHARMALINE N and X STANDARD LABELLING, STREAMLINE TAGGING & COLOUR CODING**

**Page 20**

## **PHARMALINE N and X SPECIAL USAGE CONDITIONS**

**Page 21**

## **PHARMALINE N and X QUALITY ASSURANCE, CERTIFICATION & APPROVALS**

**Page 22**

## **CORRECT HOSE CONFIGURATION & LENGTH CALCULATIONS**

- for Bend Radius **Page 23**
- for Abrasion & Torque **Page 24**
- for Length Calculation **Page 25**

## **CONDITIONS OF SALE**

**Pages 26 & 27**

# PTFE - The Optimum Choice For Hose Linings

Section from a PTFE Molecule, 16 Angstrom Units long

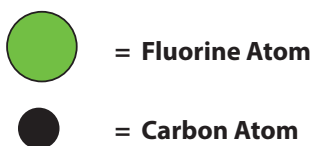
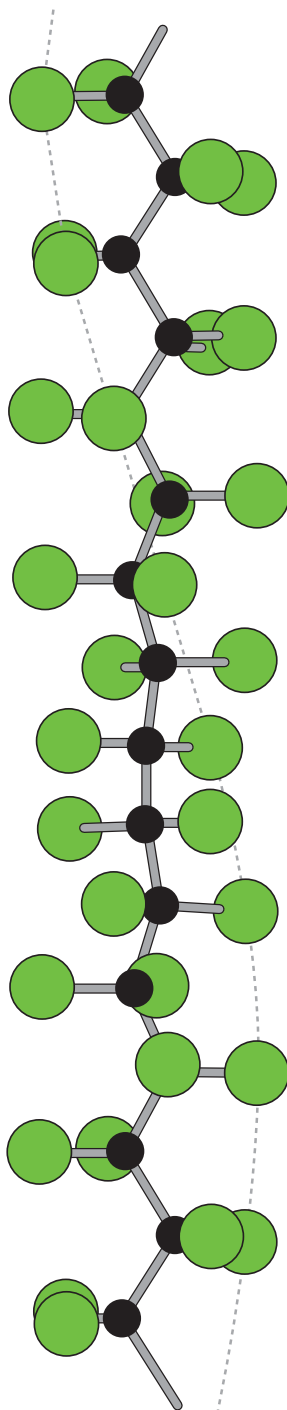

PTFE, or Polytetrafluoroethylene, comprises of long-chain molecules of carbon atoms, each linked to two fluorine atoms.

The fluorine atoms provide a helical spiral which surrounds the carbon chain and protects it.

It is this structure which creates the unique properties for which PTFE is well-known.

- **Excellent Chemical Resistance**

PTFE is renowned as the most chemically resistant material known. Only a very few, very unusual substances and conditions can affect it, like Fluorine gas at high temperature and pressure and liquid, boiling sodium metal.

PTFE lined hoses can therefore be used for a wider variety of chemicals than any other hose type, making it the ideal choice for very corrosive chemical applications and multi-product applications.

- **Non-Stick Surface**

The use of PTFE as a surface for cookware products has demonstrated to the world how easily cleanable PTFE surfaces are.

This means that PTFE lined hoses can be purged 100% clean more quickly, easily and reliably than any other type of hose.

- **Excellent Temperature Range**

The cookware application also demonstrates another of PTFE's many attributes - temperature resistance. PTFE itself can be used as a hose liner at temperatures from  $-150^{\circ}\text{C}$  up to  $+260^{\circ}\text{C}$ , dependent upon the hose design and the application conditions.

This is the widest temperature range of any rubber or plastic hose lining material.

- **Very High Electrical Resistance**

Most aerospace electrical wiring has a PTFE cover, due to the excellent electrical resistance of PTFE. This property is however, a disadvantage in some hose applications where there is a risk of developing an electrostatic charge inside the hose bore. Aflex Hose have developed a non-contaminant, FDA and USP Class VI compliant solution to this problem.

- **Hose Design**

The only issue with PTFE as a hose lining material is the best way it can be integrated in to the hose design. This is where Aflex Hose have a proven record of success over the last 40 years.

## The World's Leading Manufacturer of PTFE Flexible Hose

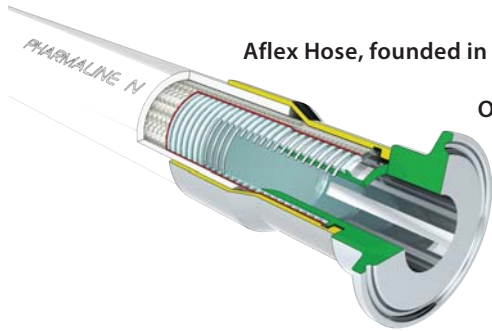

Aflex Hose, founded in 1973, pioneered the concept of PTFE lined flexible hose for the transfer of process fluids.

Over the years since then, hundreds of thousands of custom-built PTFE Lined hoses have been designed and manufactured by Aflex Hose to cope with the most difficult of operating conditions, and Aflex have continuously developed and expanded their product range having pioneered and introduced Antistatic hose, EPDM and Silicone Rubber Covered hose and many other innovations in response to customer demands.

### Total Manufacture

The primary reason for the success of the Aflex Hose range of products is that Aflex is the only PTFE hose company in the world to carry out all the hose design and manufacturing operations in house, from raw materials to finished products, at Aflex Hose plants in Yorkshire (UK) and Pennsylvania (USA).

- PTFE powder is extruded into tube and convoluted.
- Stainless steel wire is wound and braided onto the tube.
- Rubber extruders are used to apply external covers.
- End fittings are machined from bar stock on state of the art CNC lathes.
- And, finally, the hoses are assembled to individual customer requirements.

Because Aflex Hose perform all these operations in house, Aflex is able to achieve unbeatable levels of build quality, design excellence and economy of scale, which are unmatched by our competitors.

### Pharmaline N and X Hose Design

Pharmaline and Pharmalex hose were developed and introduced by Aflex Hose in 2005, specifically to provide customers with a new smooth bore, silicone covered PTFE lined hose which had better flexibility than the other products which were available commercially.

In response to customers requests, Pharmaline N and X hoses have been designed and introduced to replace Pharmaline and Pharmalex with hoses that have further improved flexibility and kink resistance. At the heart of the Pharmaline hose designs is the PTFE liner tube, smoothbore on the inside and convoluted on the outside. Most of the sizes now include a 316 SS helical reinforcing wire wound in to the convolutions, as well as an improved convolution profile. These support the tube against the effects of severe flexing and vacuum.



Technically trained Aflex Hose Sales Staff are available to respond quickly and effectively to every kind of enquiry, and to advise the optimum hose solution for any application.

### Pharmaline PTFE Liner Tube

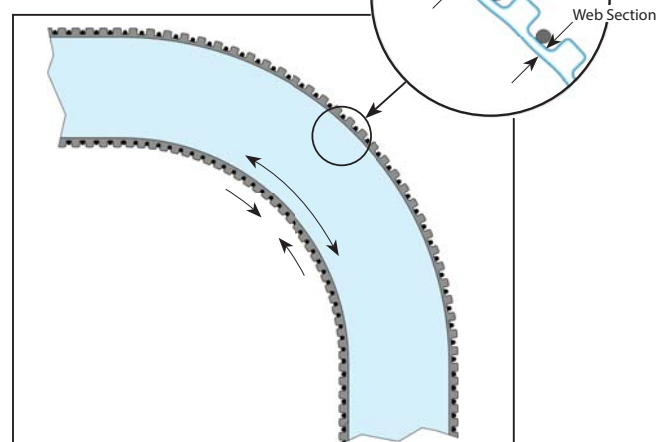

The internal surface around the inside of the bend is kept smooth by the axial compression of the rib sections against the helix wire - See 'The Inside Story' in the 'videos' section of our website [www.aflex-hose.com](http://www.aflex-hose.com).

# Pharmaline N and X Hose Descriptions

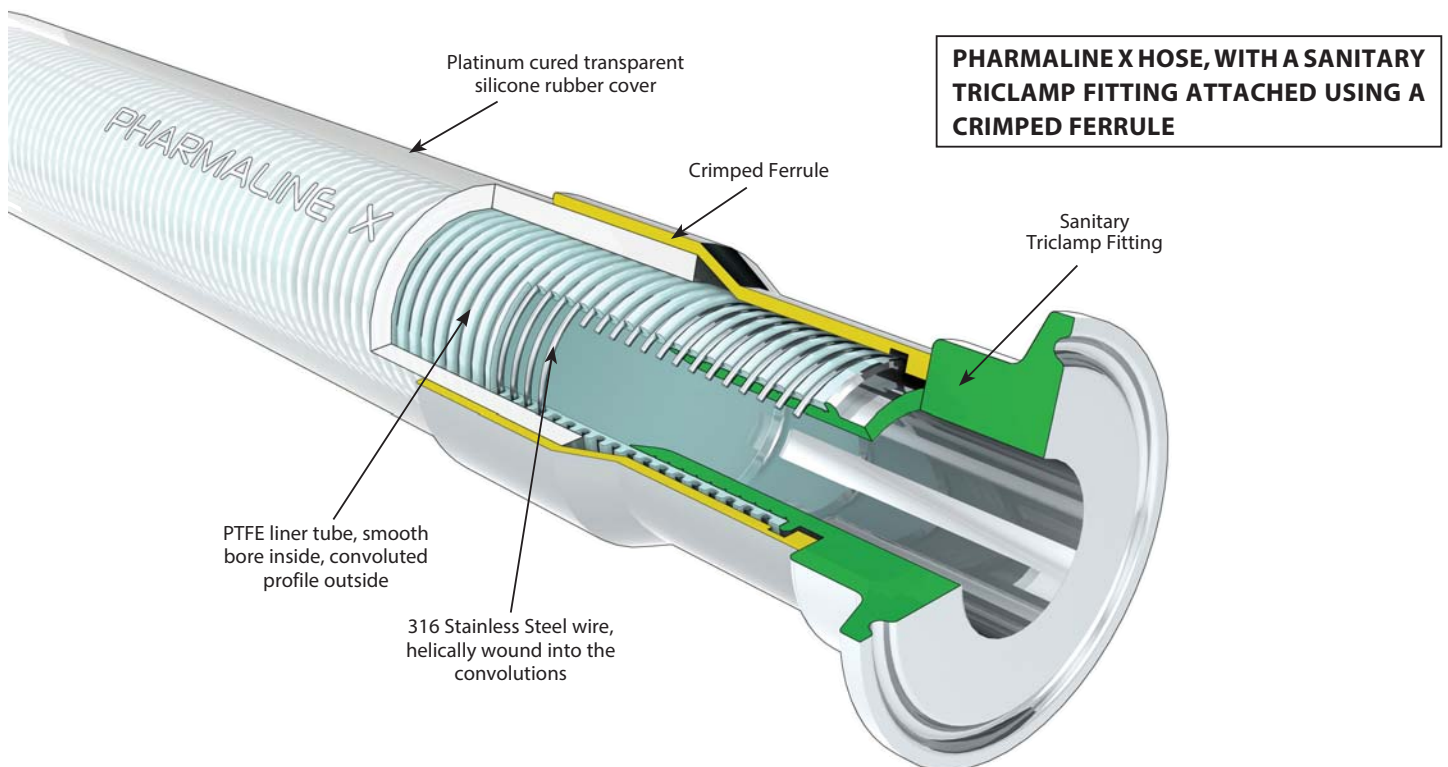
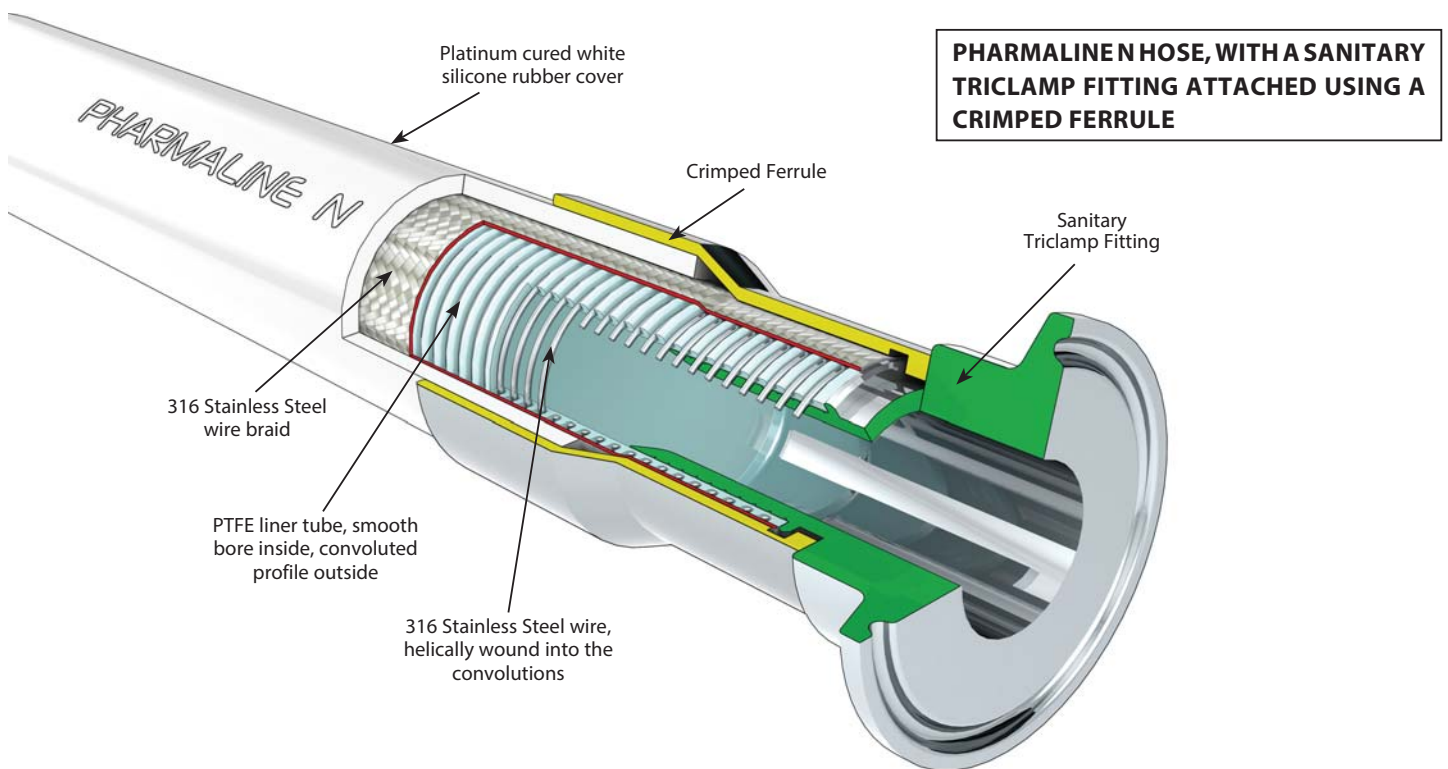

## Design Features

Pharmaline N includes a grade 316 stainless steel wire braid for additional strength and resistance to high internal pressures.

Pharmaline X does not include a braid and is designed for lighter duty, lower pressure applications.

Pharmaline N and X hose designs provide superior alternatives to silicone rubber hose and tube for use in Pharmaceutical, Biotech and Fine Chemical manufacturing and research plants. The excellent chemical resistance of the PTFE liner, and the ease of cleaning and resistance to steam sterilising represent important advantages in many applications.

# Pharmaline N and X Specifications & Properties

## Specifications for Pharmaline N Hose Grades

Nominal Hose Bore Size		Actual Hose Bore Size		Helix Wire	Outside Diameter of Cover		Minimum Bend Radius		*Maximum Working Pressure		Burst Pressure		Weight per Unit Length	
in	mm	in	mm		in	mm	in	mm	Psi	Bar	Psi	Bar	lb/ft	Kg/Mtr
1/4	6.4	0.270	6.8	-	0.460	11.6	3/4	19	1100	80	4641	320	0.11	0.17
3/8	9.5	0.375	9.5	-	0.610	15.5	1	25	1000	70	4061	280	0.14	0.22
1/2	12.7	0.530	13.5	√	0.845	21.4	1 1/2	38	870	60	3480	240	0.25	0.37
5/8	16.0	0.650	16.5	√	0.990	25.2	2	50	725	50	2900	200	0.35	0.52
3/4	19.0	0.780	19.8	√	1.120	28.5	2 1/2	63	650	45	2610	180	0.42	0.65
1	25.4	1.030	26.1	√	1.455	37.0	4	100	580	40	2320	160	0.57	0.88
1 1/4	32.0	1.280	32.5	√	1.755	44.6	5 1/4	130	500	35	2030	140	0.85	1.30
1 1/2	38.0	1.530	38.8	√	2.035	51.7	6.70	170	430	30	1740	120	1.14	1.698
2	50.0	2.030	51.5	√	2.580	65.6	8.270	210	400	28	1624	112	1.58	2.355

\* Maximum Working Pressures vary with temperature as in graph below

## Specifications for Pharmaline X Hose Grades

Nominal Hose Bore Size		Actual Hose Bore Size		Helix Wire	Outside Diameter of Cover		Minimum Bend Radius		† Maximum Working Pressure		Burst Pressure		Weight per Unit Length	
in	mm	in	mm		in	mm	in	mm	Psi	Bar	Psi	Bar	lb/ft	Kg/Mtr
1/4	6.4	0.270	6.8	-	0.456	11.6	1 1/4	30	109	7.5	435	30	0.06	0.09
3/8	9.5	0.375	9.5	-	0.610	15.5	1 1/2	38	87	6.0	348	24	0.09	0.14
1/2	12.7	0.530	13.5	√	0.845	21.4	2 3/8	60	84	5.8	334	23	0.21	0.32
5/8	16.0	0.650	16.5	√	0.990	25.2	2 1/2	64	72	5.0	290	20	0.19	0.29
3/4	19.0	0.780	19.8	√	1.120	28.5	3	75	72	5.0	290	20	0.37	0.55
1	25.4	1.030	26.1	√	1.455	37.0	4 3/4	110	60	4.0	240	16	0.44	0.81
1 1/4	32.0	1.280	32.5	√	1.755	44.6	5 1/2	120	43	3.0	175	12	0.50	0.75
1 1/2	38.0	1.530	38.8	√	2.035	51.7	7	180	29	2.0	116	8	0.74	1.11
2	50.0	2.030	51.5	√	2.580	65.6	12	300	29	2.0	116	8	1.28	1.91

† Maximum Working Pressures do not vary with temperature

### \*Maximum Working Pressures (MWP)

The lesser of the MWP for the hose and the MWP of either of the end fittings.

### Temperature Limitations

Usable from -73°C, -100°F up to +204°C, +400°F.

### Vacuum Limitations

Pharmaline N and X hose is usable at full vacuum up to 140°C, 284°F.

### Rolling U Test for Flex Life

(View this in the 'Videos' section of our website)

More than 15 x the flex life to failure compared with other types of rubber covered, smoothbore PTFE lined hose products.

### Flexibility

Much less force to bend than any other equivalent smooth bore PTFE lined hose product.

### Kink Resistance

(View this in the 'Videos' section of our website)

Much more resistant to kinking than any other equivalent smooth bore PTFE lined hose product.

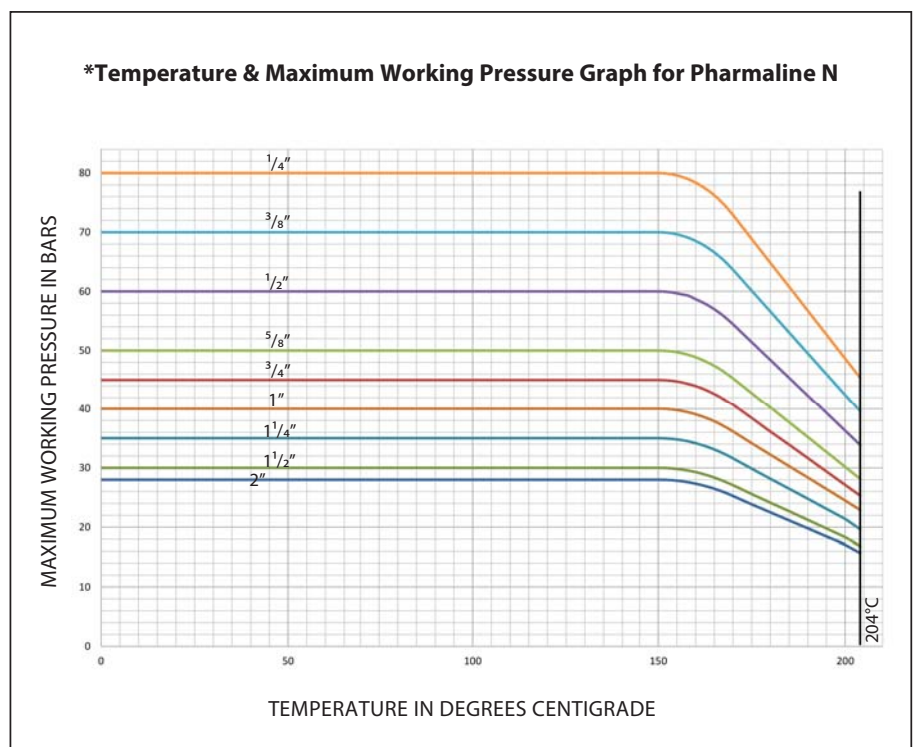

# How to order Pharmaline N and X Hose Assemblies

## Pharmaline N Hose Assemblies

Pharmaline N and X hose can be supplied loose, or as custom built hose assemblies after the hose size and grade, length and end fittings have been selected.

The specification and information contained in this brochure can be used to make these selections, but if there are any doubts concerning the hose usage limitations or performance capabilities, customers should request expert advice from Aflex Hose.

## Selecting the Hose Grade

There are two types of PTFE hose liner tube available, natural PTFE (Pharmaline N or X, GP grade), and antistatic PTFE (Pharmaline N or X, AS grade), both are fully described on page 9.

## Selecting the Hose Assembly Length

The lengths of Pharmaline N and X hose assemblies are as specified by the customer and the length is measured from the sealing face at one end fitting to the same at the other end of the hose. Length tolerances are normally +5% -0%.

Minimum hose assembly lengths are calculated by adding the lengths of the hose end fittings as listed on pages 10 to 17, the A dimensions, then adding the minimum 'visible' length of hose between the fittings as per the table below.

## Hose Assembly Length Limitations

Nominal Size of Hose		Minimum Visible Hose Length Between Fittings				Pharmaline N Maximum Hose Assembly Length		Pharmaline X Maximum Hose Assembly Length	
		Used Straight		Flexed through 90°					
in	mm	in	mm	in	mm	ft	mtrs	ft	mtrs
1/2	15	3	75	3.00	75	100	30	65	20
5/8	16	3	75	3.00	75	100	30	65	20
3/4	20	3	75	4.00	100	100	30	65	20
1	25	3	75	4.33	110	100	30	65	20
1 1/4	32	4	100	6.30	160	100	30	20	6
1 1/2	40	4	100	8.66	220	100	30	20	6
2	50	4	100	12.40	315	100	30	20	6

† Longer lengths may be available to special order - Consult Aflex Hose for details.

## How to Order

The quantity, hose type, size, grade, length and fittings must be specified in full.

**Either** by a full, written description. The hose grade can be specified by the code initials e.g. "Pharmaline N, AS" defines an antistatic PTFE lined Pharmaline N hose.

The quantity, length and fittings can then be written in - e.g. "4 off x 1" bore Pharmaline N, AS hoses x 3.00 metres long. Both ends ANSI 150# S/S Flanges".

**Or** by Part Numbers, as defined on page 8. Any special requirements relating to the hose construction, or information required on Tags, or Certificates, or special testing requirements, must be specified in full on the enquiry or purchase order.

## Conditions of Sale

Pharmaline N and X hose and hose assemblies are only supplied on the basis that the customer has read and accepted the Conditions of Sale as given on pages 26 & 27.

If the hose must be flexed, however, then there must be a sufficient length of visible hose to conform to the required flexing configuration (see pages 23 - 25).

Maximum hose assembly lengths are as per the table below.

Lengths may be stated in Feet & Inches, or decimal Metres or Millimetres. Units used must be stated.

## Selecting the End Fittings

The range of standard end fittings and materials are given on pages 10 - 17. The new DC end fitting range is introduced on page 19.

## Stainless Steel End Fitting Materials

### Non-Lined Spigots -

are all made from Grade 316L SS = EN 1.4404

### Cam and Groove Female Fittings -

are made from Grade 316C SS = EN 1.4408 (Body) and 316L SS (Spigot)

### Swivelling Nuts and Flanges -

are all made from Grade 304 SS = EN 1.4301

### Ferrules -

most ferrules are made from Grade 304 SS, otherwise Grade 316SS





# Pharmaline N and X Hose Liners

## Pharmaline N GP - General Purpose Liner

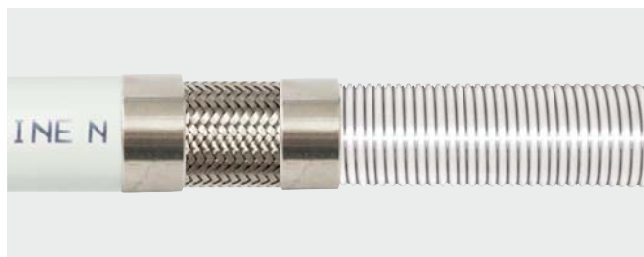

## Pharmaline X GP - General Purpose Liner



### **Purpose**

Pharmaline N or X GP hose is the 'General Purpose' grade, for use in all applications where fluids or gases are being conveyed which do not generate a risk of static charge development (see 'AS').

### **Materials & Specifications**

GP Grade has a virgin PTFE liner, manufactured from hose grade PTFE which conforms to the requirements of:

FDA 21 CFR 177.1550

Both the PTFE liner tube and the platinum cured silicone rubber covers have been tested and conform to the requirements of **USP Class VI**. Additionally, the PTFE liner tube meets the requirements of **USP Class VI** at 121°C (250°F) - see page 22.

Both the Braid and Helix wires are high tensile Grade 316L Stainless Steel.

Alternative colours for the silicone rubber cover are only available for Bioflex Ultra SI grade hose, to special order.

### **EC = Electrically Continuous, also referred to as 'Electrically Bonded'**

EC grade hose assemblies are electrically continuous, or conductive, between metal end fittings at each end of the hose. This can apply whether the hose is GP or AS grade.

The requirements for this are specified in the German Document BRG 132 and EN ISO 8031 Annex A, when tested in accordance with EN ISO 8031, which requires that the resistance between end fittings shall be  $<10^2$  ohms per assembly. For hose assemblies which meet this requirement a Grade 'M' marking can be applied in accordance with EN ISO 8031 Annex A if requested.

**Pharmaline N hose assemblies are normally EC, and Pharmaline X are not EC, but if EC or not EC is a specific requirement for either hose, it must be stated on the enquiry/order.**

## Pharmaline N AS - Anti-Static PTFE Liner



## Pharmaline X AS - Anti-Static PTFE Liner



### **Purpose**

Pharmaline N or X AS Grade is an essential requirement in applications where there is the risk of an electrostatic charge build-up on the inside surface of the PTFE tube which may then discharge through the tube wall. Media passing through which create such a risk are fluids which have a Conductance of less than  $10^{-8}$  S/m (Siemens per Metre), or  $10^{-4}$  pS/m such as fuels, solvents, freons, some WFI (ultra-pure "Water for Injection") and non-polar organics which are being transferred at a medium to high flow velocity.

All twin or multi phase media, and any non-mixing media, such as powder in air, or water droplets in steam, in gases or in oil, also colloidal fluids constitute a particular hazard for static charge generation, and always require grade AS.

### **Materials & Specifications**

Pharmaline N and X AS Grade hose has a black anti-static PTFE liner manufactured from FDA 21 CFR 177.1550 approved PTFE, and less than 2.5% of "high purity" Carbon Black material to FDA requirement 21 CFR 178.3297 and European Commission Directive 2007/19/EC. AS Grade also conforms to the requirements of USP Class VI, at 37°C (99°F), 70°C (158°F) and 121°C (250°F) - see page 22.

### **Antistatic Hose Assemblies**

When 'AS' (Antistatic) grade hose is specified, then the hose or hose assembly supplied will be tested in accordance with EN ISO 8031 and meet the Antistatic requirements of EN ISO 8031 Annex A. This requires, for an antistatic liner or antistatic cover, that the resistance between an appropriately placed foam electrode and a metallic end fitting will be between  $10^3$  to  $10^8$  ohms per assembly. For hose assemblies which meet these requirements an appropriate Grade 'Ω' marking can be applied in accordance with EN ISO 8031 Annex A if requested.

**NOTE:** When in service, at least one end fitting must be connected to earth, to permit dissipation of the static charge from the end fitting.

# Pharmaline N and X Non-Lined Swivel Flange Fittings

## End Fitting Specifications

- ANSI, also ASME B16.5 Class 150# and 300#, previously ASA 150 and 300
- DIN PN10, PN16 and PN40\*
- JIS 10K
- Other Pressure Ratings and Flange Specifications are also available.

\*DIN PN10, PN16 and PN40 Flanges all have the same dimensions, and so are fully interchangeable

## End Fitting Materials

- Flanges normally in Grade 304 SS = EN 1.4301
- Flange Retainers in Grade 316L SS = EN 1.4404
- Ferrules, most in Grade 304 SS, some sizes in Grade 316 SS

## Alternative Options for Flange Component only:

- Zinc Plated Carbon Steel
- Grade 316 SS

## Surface Finish :

- All surface finishes are to ASME BPE-SF-O
- If a specified finish on a particular surface is required, please state on the enquiry and order.

## Temperature and Pressure Ratings

- ANSI 150# = 16 Bar (230 psi),  
ANSI 300# = 41.4 Bar (600 psi)
- DIN PN10 = 10 Bar (145 psi),  
DIN PN16 = 16 Bar (230 psi)  
DIN PN40 = 40 Bar (580 psi)

**Note:** The fitting design on this page is to the current Old Style (OS) fitting design. An alternative Direct Crimp (DC) fitting option is also available which can be assembled without stripping the rubber at the hose ends, see pg 19.

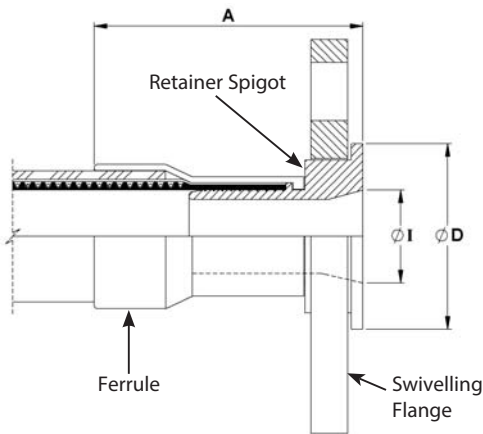

The above drawing relates to sizes 1", 1 1/2", 2"

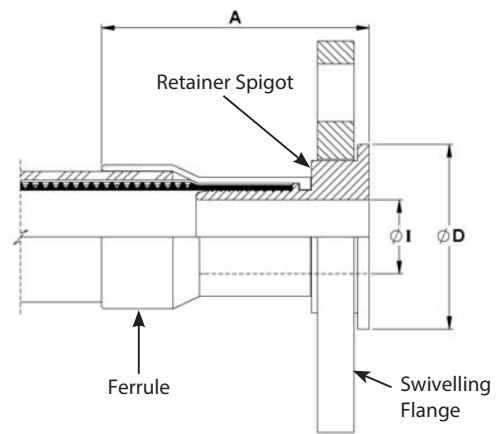

The above drawing relates to all other sizes

Nominal Hose Size		Fitting Length A ASA150		Flared Diameter D ASA150		Fitting Inside Diameter I ASA150		Weight of Fitting	
in	mm	in	mm	in	mm	in	mm	Kg	Lbs
1/2	13	2.80	71	1.38	35.00	0.38	9.53	0.77	1.69
3/4	20	3.15	80	1.69	42.90	0.63	15.88	1.061	2.35
1	25	3.27	83	2.00	50.80	0.79	20.24	1.361	3.00
1 1/4	32	3.97	101	2.50	63.5	1.03	26.2	2.53	5.58
1 1/2	40	4.09	104	2.87	73.00	1.25	31.75	2.49	5.50
2	50	4.17	106	3.62	92.00	1.75	44.45	3.57	7.87

Nominal Hose Size		Fitting Length A PN10/16		Flared Diameter D PN10/16		Fitting Inside Diameter I PN10/16		Weight of Fitting	
in	mm	in	mm	in	mm	in	mm	Kg	Lbs
1/2	13	2.87	73	1.77	45.00	0.38	9.53	0.77	1.69
3/4	20	3.27	83	2.28	58.00	0.63	15.88	1.061	2.35
1	25	3.58	91	2.68	68.00	1.12	28.50	1.361	3.00
1 1/4	32	4.17	106	3.07	78.00	1.03	26.2	2.29	5.05
1 1/2	40	4.53	115	3.49	88.00	1.70	43.10	2.49	5.50
2	50	4.49	114	4.02	102.00	2.15	54.50	3.57	7.87

# Pharmaline N and X Female Cam & Groove Fittings and Male Cam & Groove Fittings

## End Fitting Specifications

- Generally in accordance with A-A-59326 (replaces MIL-C-27487) and EN14420-1 (replaces DIN 2828), and all are fully interchangeable.

## Temperature and Pressure Ratings

- When used with a Buna N Gasket all sizes up to 16 Bar (230 psi) and up to a maximum temperature of 65°C (149°F).
- When used with FEP, Fluoro Rubber or other encapsulated gaskets all sizes up to 10 Bar (145 psi) and up to a maximum temperature of 204°C (400°F)

**Note:** The fitting design on this page is to the current Old Style (OS) fitting design. An alternative Direct Crimp (DC) fitting option is also available which can be assembled without stripping the rubber at the hose ends, see pg 19.

## End Fitting Materials

- Spigot in Grade 316L SS = EN 1.4404
- Body in Grade 316C SS = EN 1.4408
- Ferrules, most in Grade 304 SS, some sizes in Grade 316L SS
- Standard Gasket is Buna N (Nitrile) Rubber.
- FEP encapsulated Silicone Rubber Gaskets also available.

## Surface Finish :

- All surface finishes are to ASME BPE-SF-O (No finish required).
- If a specified finish on a particular surface is required, please state on the enquiry and order.

## Swivelling, Locking Arm Female Cam and Groove Fittings - Non-Lined

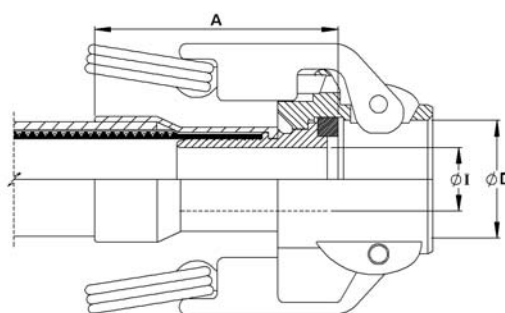

Nominal Hose Size		Fitting Length A		Cam Sleeve Inside Diameter D		Fitting Inside Diameter I		Weight of Fitting	
in	mm	in	mm	in	mm	in	mm	Kg	Lbs
3/4	20	3.22	82.0	1.260	32	0.625	15.88	0.54	1.19
1	25	3.39	86.5	1.456	37	0.797	20.24	0.71	1.56
1 1/4	32	3.86	98.0	1.81	46	1.03	26.21	1.20	2.64
1 1/2	40	3.97	101.0	2.126	54	1.25	31.75	1.23	2.71
2	50	4.09	104.0	2.520	64	1.75	44.45	1.52	3.35

## Non-Lined Cam & Groove Male Fitting

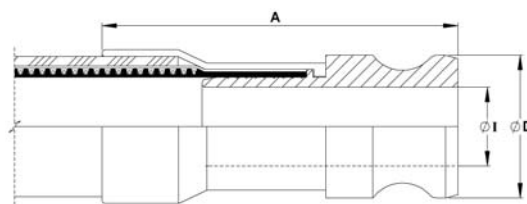

Nominal Hose Size		Outside Diameter D		Non-Lined Fitting Length A		Non-Lined Inside Diameter I		Weight of Fitting	
in	mm	in	mm	in	mm	in	mm	Kg	Lbs
3/4	20	1.260	32.0	3.48	88.5	0.625	15.88	0.35	0.77
1	25	1.456	37.0	3.94	100	0.80	20.24	0.45	0.99
1 1/4	32	1.79	45.5	N/A	N/A	N/A	N/A	0.45	1.09
1 1/2	40	2.106	53.5	4.86	123.5	1.25	31.75	0.84	1.85
2	50	2.480	63.0	5.47	139	1.75	44.45	1.10	2.42

# Pharmaline N and X Sanitary & Mini-Sanitary Triclover Fittings

PHARMALINE N

## Introduction

There are many different specifications, dimensions and surface finishes for triclamp fittings. Those listed below are the popular fittings, which are stocked as standard fittings by Aflex.

All the alternative fittings can be supplied to special order if the following information can be given;

- Flange diameter D and Outlet diameter I
- Hose size if known, or Aflex can recommend a hose size to suit
- The internal Surface Finish, if it is required to be better than the ASME BPE SF3 surface finish of  $<0.76\mu\text{m Ra} = <30\mu\text{ in Ra}$  non-electropolished.
- Standard (see below) if known.

## Standards

- ASME BPE
- DIN 32676 (types A, B and C are available)
- BS 4825 Pt.3 (equivalent to ASME BPE)
- ISO 1127

**Note:** The fitting design on this page is to the current Old Style (OS) fitting design. An alternative Direct Crimp (DC) fitting option is also available which can be assembled without stripping the rubber at the hose ends, see pg 19.

## Temperature and Pressure Ratings

- Pressures up to 16 Bar (230 psi)
- Temperatures up to 120°C (250°F) with EPDM Gaskets
- Temperatures up to 180°C (356°F) with PTFE, Silicone or Viton Gaskets
- Higher Pressures and Temperatures with Special Clamps and Gaskets.

## End Fitting Materials

- Fittings in AISI 316L = EN 1.4404 = BS 316 S11
- Ferrules, most in Grade 304 SS, some sizes in Grade 316L SS
- Fittings for DIN32676 are available in 1.1435 (316L)
- Fittings in 1.4571, Hastelloy, Monel, PVDF and other materials to special order

## Internal Surface Finish Specifications

- ASME BPE SF3 (mechanical polish, not electropolished) Surface Finish, Maximum reading:  $<0.76\mu\text{m Ra} = <30\mu\text{ in. Ra}$
- ASME BPE SF4 (mechanical polish and electropolished) Surface Finish, Maximum reading:  $<0.375\mu\text{m Ra} = <15\mu\text{ in. Ra}$  (SF4 is the highest level of surface finish specified in ASME BPE, and the standard, stocked fittings listed are all to this finish).
- DIN 32676 H4 (mechanical polish, not electropolished) Surface Finish, Average reading:  $<0.4\mu\text{m Ra} = <16\mu\text{ in. RA}$  If the standard SF4 finish is not acceptable, H4 must be requested on the enquiry/order.

**Note:** ASME BPE Triclamp suppliers often quote an 'Average' of surface finish reading only, for example 'average 15 Ra or better', but this is not in accordance with the stricter ASME BPE requirement that a 'Maximum' for individual readings should be complied with.



Mini-Sanitary Triclamp Fittings	Nominal Hose Size		Flange Diameter D		Outlet Diameter I		Fitting Length A		Specifications	
	in	mm	in	mm	in	mm	in	mm	ASME BPE	DIN 32676
	1/4	6.35	0.984	25.0	0.172	4.37	2.4	61	-SF4	-
	1/4	6.35	0.984	25.0	3/8	9.53	2.4	61	-SF4	Type C
	3/8	9.53	0.984	25.0	0.305	7.75	2.6	66	-SF4	-
	3/8	9.53	0.984	25.0	3/8	9.53	2.6	66	-SF4	Type C
	1/2	12.7	0.984	25.0	5/8	15.88	2.8	72	-SF4	Type C
	1/2	12.7	0.984	25.0	3/8	9.5	2.8	72	-SF4	Type C
	3/4	19.05	0.984	25.0	5/8	15.85	3.1	79	-SF4	Type C

Sanitary Triclamp Fittings	3/4	19.05	1.340	34.0	5/8	15.88	3.0	77	-SF4	Type C
	3/4	19.05	1.340	34.0	0.630	16.0	3.0	77	-	Type A
	1/2	12.7	1.984	50.5	7/8	22.2	2.8	72	-SF4	Type C
	1/2	12.7	1.984	50.5	1 3/8	34.8	2.8	72	-SF4	Type C
	3/4	19.05	1.984	50.5	0.713	18.1	3.0	77	ISO1127	Type B
	3/4	19.05	1.984	50.5	7/8	22.1	3.0	77	-SF4	Type C
	3/4	19.05	1.984	50.5	5/8	15.88	3.0	77	-SF4	Type C
	1	25.4	1.984	50.5	7/8	22.2	3.2	82	-SF4	Type C
	1	25.4	1.984	50.5	1 3/8	34.8	3.2	82	-SF4	Type C
	1 1/2	38.1	1.984	50.5	1 3/8	34.8	3.9	98	-SF4	Type C
	1 1/2	38.1	2.516	64.0	1 7/8	47.6	3.9	98	-SF4	Type C
	2	50.8	2.516	64.0	1 7/8	47.6	4.1	103	-SF4	Type C

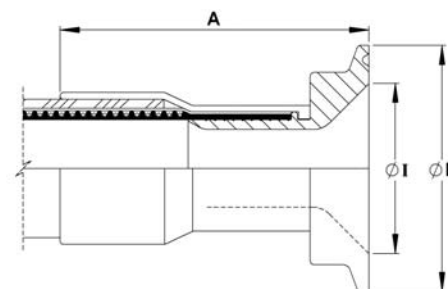
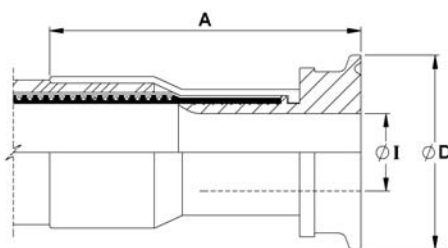
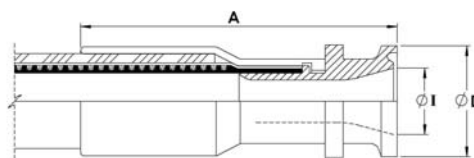
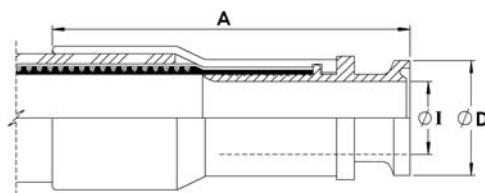

Mini-Sanitary Triclamp Fittings

Sanitary Triclamp Fittings

# Pharmaline N and X Sanitary Triclover Fittings - 90° Elbow

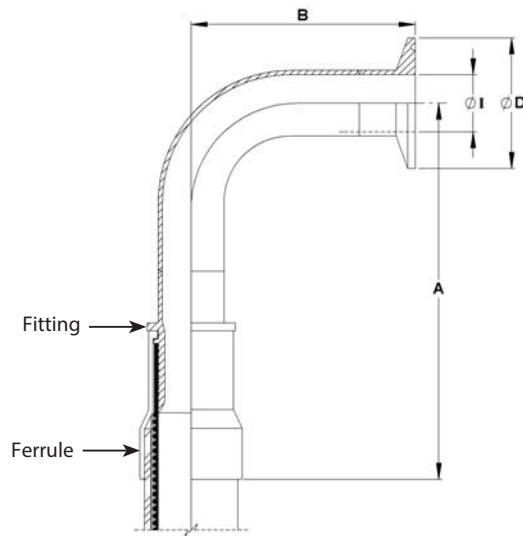

## End Fitting Specifications

- BS4825 Pt 3
- ASME-BPE-a
- Others to Special Order

## End Fitting Materials

- Fittings in Grade AISI 316L = EN 1.4404 = BS 316 S11
- Ferrules, most in Grade 304 SS, some sizes in Grade 316L SS

## Surface Finish :

- The internal surface is to ASME BPE-SF-3 (<0.76 µm Ra, not electropolished).
- If a specified finish on a particular surface is required, please state on the enquiry and order.

**Note:** The fitting design on this page is to the current Old Style (OS) fitting design. An alternative Direct Crimp (DC) fitting option is also available which can be assembled without stripping the rubber at the hose ends, see pg 19.

## Outlet Diameters

The outlet diameters as listed are in accordance with BS4825. The ASME specification, however, requires these diameters to be 0.005" (0.125mm) less in each case. An Outlet Diameter tolerance of +0.000 -0.005" has therefore been applied, so that the same fitting satisfies requirements of both specifications.

## Temperature and Pressure Ratings

- Pressures up to 16 Bar (230 psi)
- Temperatures up to 120°C (250°F) with EPDM Gaskets
- Temperatures up to 180°C (356°F) with PTFE, Silicone or Viton Gaskets
- Higher Pressures and Temperatures with Special Clamps and Gaskets.

Nominal Hose Size		Centre Line to Fitting End A		Centre Line to Face B		Flange Diameter D		Outlet Diameter I		Weight of Fitting	
in	mm	in	mm	in	mm	in	mm	in	mm	Kg	Lbs
1/2	13	5.78	147	1.60	41.0	0.984	25.0	3/8	9.5	0.13	0.30
3/4	20	6.41	163	1.60	41.0	0.984	25.0	5/8	16.0	0.20	0.45
1	25	6.53	166	2.00	51.0	1.984	50.5	7/8	22.2	0.35	0.77
1 1/2	40	7.99	203	2.75	70.0	1.984	50.5	1 3/8	34.9	0.59	1.30
2	50	9.33	237	3.50	88.9	2.16	64.0	1 7/8	47.6	0.93	2.05

# Pharmaline N and X NPT and BSPT Fixed Male & NPT Fixed Female Fittings

## End Fitting Specifications

- NPT Taper Threads to American National Standard Pipe Taper Thread design to ANSI/AMSE B1.20.1.
  - BSPT Threads to British Standard Pipe Taper Thread design to BS21
- Alternatives: Parallel Threads, Metric Threads and Others.

## End Fitting Materials

- Fittings in Grade 316L SS = EN 1.4404
- Ferrules, most in Grade 304 SS = EN 1.4301, some sizes in Grade 316L SS
- Available in other materials to special order

## Surface Finish :

- All surface finishes are to ASME BPE-SF-O (No finish required).
- If a specified finish on a particular surface is required, please state on the enquiry and order.

## Temperature and Pressure Ratings

- As for the relevant size of hose on Page 6.

**Note:** The fitting design on this page is to the current Old Style (OS) fitting design. An alternative Direct Crimp (DC) fitting option is also available which can be assembled without stripping the rubber at the hose ends, see pg 19.

## Fixed Male NPT or BSPT

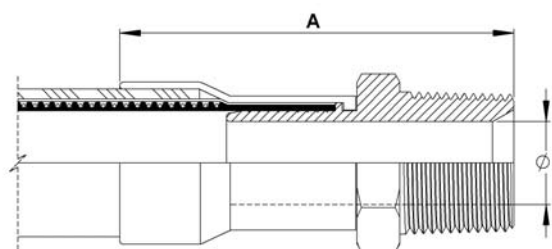

Nominal Hose Size		NPT or BSPT Thread Size	Fitting Length A		Fitting Inside Diameter I		Weight of Fitting	
in	mm		in	mm	in	mm	Kg	Lbs
1/2	13	1/2	3.30	84	0.38	9.53	0.10	0.22
3/4	20	3/4	3.74	95	0.63	15.88	0.18	0.40
1	25	1	4.13	105	0.80	20.24	0.29	0.64
1 1/4	32	1 1/4	4.90	124	1.00	25.40	0.45	0.99
1 1/2	40	1 1/2	5.19	132	1.25	31.75	0.60	1.32
2	50	2	5.78	142	1.75	44.45	0.84	1.85

## Fixed Female NPT

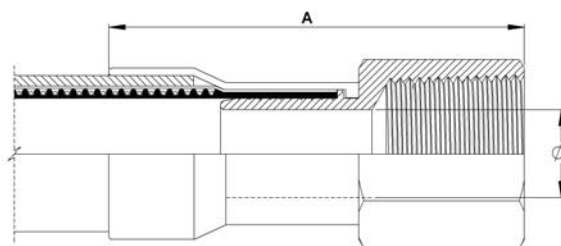

Nominal Hose Size		NPT Thread Size	Fitting Length A		Fitting Inside Diameter I		Weight of Fitting	
in	mm		in	mm	in	mm	Kg	Lbs
1/2	13	1/2	3.42	87	0.38	9.53	0.18	0.40
3/4	20	3/4	3.66	93	0.63	15.88	0.22	0.49
1	25	1	4.13	105	0.80	20.24	0.33	0.73
1 1/2	40	1 1/2	4.80	122	1.25	31.75	0.75	1.65
2	50	2	4.96	126	1.75	44.45	1.06	2.34

# Pharmaline N and X BSP 60° Cone Seat Female Unions and BSP Flat Seat Lug Nut Female Fittings

## End Fitting Specifications

- BSPP Threads to British Standard Pipe Parallel Thread design to BS21, 60° Cone Seat design, or Flat Seat.

## End Fitting Materials

- Spigots in Grade 316L SS
- Nuts in Grade 316L SS
- Ferrules, most in Grade 304 SS, some sizes in Grade 316L SS

## Surface Finish :

- All surface finishes are to ASME BPE-SF-O (No finish required).
- If a specified finish on a particular surface is required, please state on the enquiry and order.

## Alternatives:

- Lug Nuts can be supplied in Gun Metal (Bronze) if required.

## Male/Male Adaptors:

- Cone Seat Female Union Fittings can be supplied fitted with a BSPP BSPT Taper Male/Male Adaptor if required.

## Temperature and Pressure Ratings

- As for the relevant size of hose on Page 6.

**Note:** The fitting design on this page is to the current Old Style (OS) fitting design. An alternative Direct Crimp (DC) fitting option is also available which can be assembled without stripping the rubber at the hose ends, see pg 19.

## BSP 60° Cone Seat Female Union Fitting

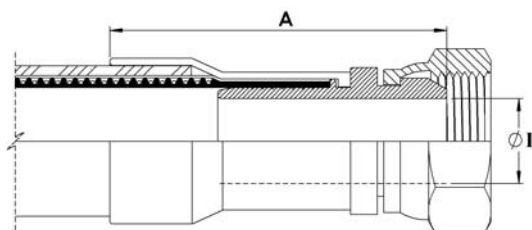

Nominal Hose Size		NPT or BSPT Thread Size	Fitting Length A		Fitting Inside Diameter I		Weight of Fitting	
in	mm		in	mm	in	mm	Kg	Lbs
1/2	13	1/2	3.27	83	0.37	9.35	0.11	0.25
3/4	20	3/4	3.62	92	0.63	15.88	0.15	0.34
1	25	1	3.86	98	0.80	20.24	0.24	0.53
1 1/4	32	1 1/4	3.98	101	1.03	26.21	0.46	1.01
1 1/2	40	1 1/2	4.65	118	1.25	31.75	0.72	1.59
2	50	2	4.80	122	1.75	44.45	0.99	2.19

## BSP Flat Face Lug Nut Female Fitting

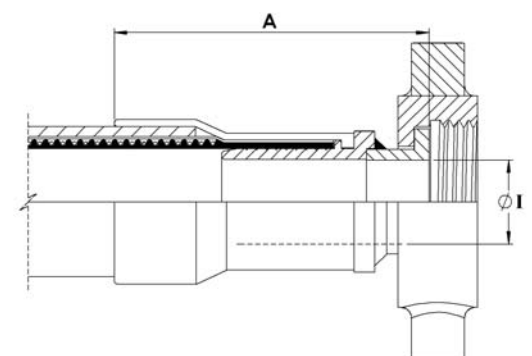

Nominal Hose Size		BSPP Thread Size	Fitting Length A		Fitting Bore Diameter I		Weight of Fitting	
in	mm		in	mm	in	mm	Kg	Lbs
1	25	1	3.70	94	0.80	20.24	0.25	0.55
1 1/2	40	1 1/2	3.66	93	1.25	31.75	0.61	1.33
2	50	2	3.70	94	1.75	44.45	0.88	1.95

# Pharmaline N and X 37° JIC Female Fittings and NPT Male & Female Unions

## 37° JIC Female Fitting

### End Fitting Specifications

- SAE J514 37° Flare JIC Female Fitting
- 37° JIC Male-to-NPT Male/Female Adaptors
- NPT Threads to ANSI/AMSE B1.20.1

### Temperature and Pressure Ratings

- As for the relevant size of Hose, on page 6.

### Note:

- Not usable with SAE 45° Flare fittings which have the same thread.
- The fitting design on this page is to the current Old Style (OS) fitting design. An alternative Direct Crimp (DC) fitting option is also available which can be assembled without stripping the rubber at the hose ends, see pg 19.



### End Fitting Materials

- Spigots in Grade 316L SS
- Nuts in 316L SS
- Ferrules, most in Grade 304 SS, some sizes in Grade 316L SS

### Alternatives:

- Available in other materials to special order

### Surface Finish :

- All surface finishes are to ASME BPE-SF-O (No finish required).
- If a specified finish on a particular surface is required, please state on the enquiry and order.

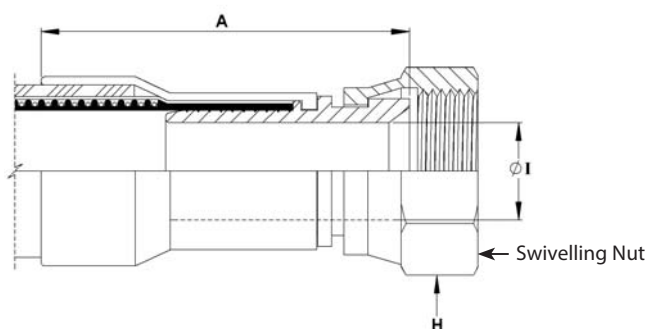

Nominal Hose Size		37° JIC Thread Size	Fitting Length A		Hex Size H		Fitting Inner Diameter I		Weight of Fitting	
in	mm	in	in	mm	in	mm	in	mm	Kg	Lbs
1/2	13	3/4 - 16	2.76	70	0.88	22.2	0.38	9.5	0.11	0.24
3/4	20	1 1/16 - 12	3.07	78	1.25	31.7	0.63	15.9	0.15	0.34
1	25	1 5/16 - 12	3.23	82	1.50	38.1	0.80	20.2	0.23	0.52
1 1/2	40	1 7/8 - 12	4.00	102	2.25	57.1	1.25	31.7	0.72	1.58
2	50	2 1/2 - 12	4.33	110	2.88	73.0	1.75	44.4	0.99	2.18

## JIC to NPT Male Union (including a JIC Male to NPT Male Adaptor)

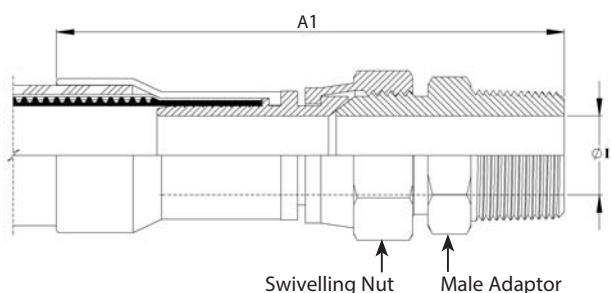

Nominal Hose Size		Male Union Length A1		Weight of Fitting	
in	mm	in	mm	Kg	Lbs
1/2	13	4.13	105	0.22	0.48
3/4	20	4.92	125	0.33	0.72
1	25	5.43	138	0.52	1.15

## JIC to NPT Female Union (including a JIC Male to NPT Female Adaptor)

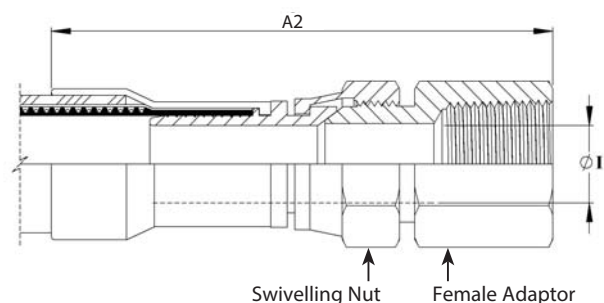

Female Union Length A2		Fitting Inner Diameter I		Weight of Fitting	
in	mm	in	mm	Kg	Lbs
4.25	108	0.38	9.5	0.21	0.47
4.80	122	0.63	15.9	0.33	0.74
5.12	130	0.80	20.2	0.68	1.50



# Pharmaline N and X Tube Adaptor (Grooved Standpipe) Fittings

## Non-Lined Tube Adapter (Grooved Standpipe) Fitting

### End Fitting Specifications

- Compatible with existing Industrial Standard Tube Fitting Components.

### Temperature & Pressure Ratings

- As for the relevant size of hose on Page 6.

**Note:** The fitting design on this page is to the current Old Style (OS) fitting design. An alternative Direct Crimp (DC) fitting option is also available which can be assembled without stripping the rubber at the hose ends, see pg 19.

### End Fitting Materials

- Fitting in grade 316L SS
- Ferrule (for hose attachment) in Grade 304 or 316L SS

### Alternatives:

- can be supplied with matching Female nuts & Ferrules (clamping Ferrules) to suit.

### Surface Finish :

- All surface finishes are to ASME BPE-SF-O (No finish required).
- If a specified finish on a particular surface is required, please state on the enquiry and order.

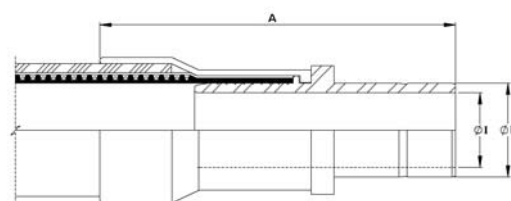

Nominal Hose Size		Fitting Length A		Diameter D		Fitting Inside Diameter I		Weight of Fitting	
in	mm	in	mm	in	mm	in	mm	Kgs	Lbs
3/4	20	3.10	79.0	3/4	19.05	0.58	14.70	0.18	0.40
1	25	3.58	91.0	1	25.4	0.80	20.32	0.20	0.44

# Pharmaline N and X Dip Pipes, Straight or 90° Elbow

## Fixed Dip Pipes

### Description

Fixed Dip Pipes are fairly rigid, thick wall PTFE tubes, either straight or 90° elbowed, which are directly crimped to the end of Pharmaline N hoses. They are designed for insertion into drums, tanks and reaction vessels in order to suction drain (or inject) process fluids transferred through the hose.

### Materials

- Standard dip pipes are in anti-static (AS) PTFE
- Ferrules, most in Grade 304 SS, some sizes in Grade 316L SS

### How to order

Specify the size and material of the dip pipe, whether it is straight or 90° elbowed. Give the length of the straight leg of the dip pipe and the length of the rest of the hose assembly separately.

### Maximum Working Pressures

Dip Pipes are normally only tested to 4 Bar Pressure, and are not suitable for use at pressures higher than 3 Bar. They are usable at negative pressure up to full vacuum.

If higher pressure ratings are required, consult Aflex Hose.

### Lengths

Dip Pipes are supplied as standard in 1 metre straight lengths, but can be supplied in any length to individual requirements.

## Fixed Dip Pipe (90° Elbow)



## Fixed Dip Pipe (Straight)

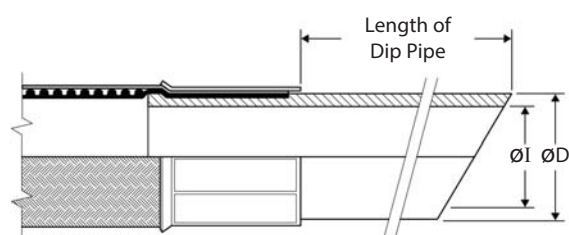

Nominal Hose Bore Size		Approximate Dip Pipe Dimensions			
		Outside Diameter D		Inside Diameter I	
in	mm	in	mm	in	mm
3/4	20	0.87	22	0.51	13
1	25	1.14	29	0.83	21
1 1/2	40	1.54	39	1.00	27
2	50	2.17	55	1.58	40

## Detachable Dip Pipes

### Description

As Fixed Dip Pipes above, but connected to the hose through an end fitting, not by crimping direct to the hose.

### Design

A straight, or 90° elbowed anti-static PTFE Dip Pipe, fitted with a Flange or Cam & Groove Male PTFE Lined & Flared end fitting.

The most usual end fitting is a Cam Male (as shown), so the dip pipe can then be connected to a hose with a Cam Female end fitting.

### Specifications

As above for Fixed Dip Pipes

## Detachable Dip Pipe

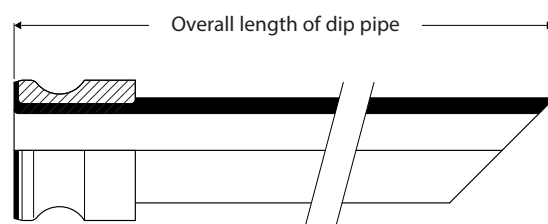

# Pharmaline N or X Hose Assembled with Direct Crimp(DC) End Fittings

PHARMALINE N GP HOSE, FITTED WITH DIRECT CRIMP(DC) NON-LINED TRICLAMP FITTING

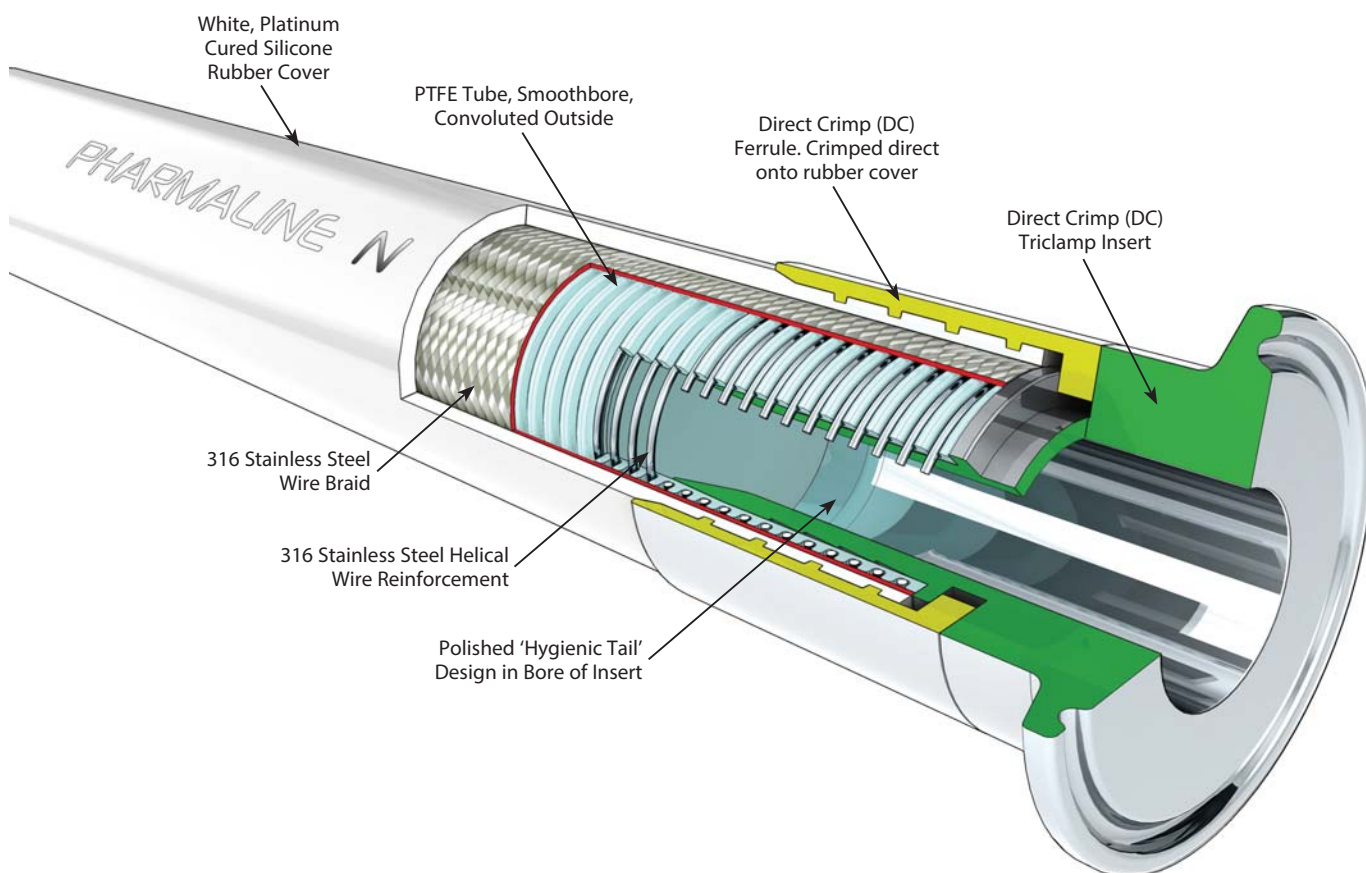

## Introduction

All the non-lined end fittings shown on the previous pages in this brochure have the current Old Style (OS) fitting design, and they are assembled by stripping off the rubber at the ends so that the OS design ferrule can be crimped on to the braid.

An alternative design has been developed for Pharmaline N or X hose which uses an Aflex designed Direct Crimp (DC) end fitting and ferrule. The advantage is that with DC fittings there is no need to strip the rubber, because the DC ferrule can be crimped directly on to the rubber instead of on to the braid. This permits easy 'Cut, Fit and Crimp' assembly of end fittings.

DC fittings are available from Aflex Hose, hose inserts in grade 316 stainless steel, and ferrules in grade 304 stainless steel.

**Note:** When using DC fittings with Pharmaline X the maximum operating temperatures are reduced to -40°C to +180°C.

# Pharmaline N and X Standard Labelling, Streamline Tagging and Colour Coding Systems

## Standard Labelling



All Pharmaline N and X hose assemblies are labelled with the following information:

- Manufacturer's Name (Aflex Hose Ltd)
- Hose Type, Size and Grade
- Max. Working Pressure
- Unique Serial Number
- Month & Year of Manufacture
- Aflex Hose Telephone Number
- CE Mark (if applicable)

This information is normally laser-etched on to a ferrule.

In some cases, at the discretion of Aflex Hose, the information may be etched on to a stainless steel ring, or a thin stainless steel plate which is clamped to the hose. This may be necessary for example, if the customer requires additional information which may not fit on to a Ferrule.

## Streamline Tagging



A label and/or Colour Code is placed around the silicone cover of the hose and then encapsulated by a transparent silicone that is formed into a thin streamlined cover.

Note: 1/4" size, Colour Code only, no text.

## Colour Coding



A coloured PTFE spiral strip is wound on to the hose.

It can be left loose, or it can be encapsulated under a transparent, heat-shrunk polyolefin sleeve.



# Pharmaline N and X Hose: Special Usage Conditions

## • **Cleaning & Sterilising Systems - CIP, SIP and Autoclave**

CIP & SIP – PTFE liner tubes are chemically resistant to all CIP, SIP and Autoclave conditions. A primary consideration is whether the cleaning and purging cycle is likely to develop an electrostatic charge on the internal surface of the liner, in which case AS (Anti-Static) grade hose is required.

AS grade hose and Electrostatic charge generating systems are fully described in the hose liner section.

CIP systems using high electrical resistivity solvents like Toluene will require AS grade hose.

Another electrostatic generation problem arises when wet steam is passed through, or when the cleaning fluids or WFI are purged out of the line using nitrogen, compressed air or another gas, because droplets of liquid or water in the gas then generate a multi-phase condition until they are cleared out, which will generate a static charge, and so will require AS grade hose.

## • **Autoclave**

Pharmaline N hose is able to withstand at least 300 x 30 minute autoclave cycles at relatively high autoclave temperatures (up to 135°C, 275°F). Please note that in robust applications the Silicone cover may become more susceptible to tearing after extended autoclave cycles. Consult Aflex Hose for more specific information.

## • **PTFE Hose-Use with Alkali Metals, Halogens and certain Halogens containing Chemicals**

PTFE hose liners react chemically with Fluorine, Chlorine Trifluoride and molten Alkali Metals and so no hose grades are suitable for use with these chemicals.

When PTFE lined hose is used to carry Chlorine or Bromine, either as gasses or fluids, trace quantities can diffuse into and through the PTFE liner wall thickness. These will then combine with atmospheric moisture to corrode the SS braid or rubber cover outside the liner tube. It has been found that Corroflon SP, HB or KYB hose is best suited for these applications - Please consult the Corroflon brochure.

Depending upon the internal pressures and temperatures, some other gasses and fluids with a high halogen content may also be transmitted in trace quantities through the wall of the PTFE tube, including Hydrogen Fluoride, Hydrogen Chloride, Carbonyl Chloride (Phosgene), Carbon Tetrachloride and others. Please consult with Aflex Hose for a suitable hose grade recommendation.

## • **Other “Penetrating” Fluids and Gases**

Sulphur Trioxide, Methyl Methacrylate, Caprolactam and Glacial Acetic Acid are some other chemicals which do not react chemically with the PTFE, but which can be absorbed and transmitted in trace quantities through the PTFE liner tube wall - please consult Aflex Hose for the optimum solution with these chemicals.

Generally, however, as a hydrophobic (non-wetting) material, PTFE is very resistant to the absorption of chemicals. In some cases, PTFE has superior resistance to diffusion, for example to the diffusion of automotive fuels, in comparison with all other plastics and rubbers.

## • **Gas/Fluid Cycling**

There are some applications where fluids then gasses are passed through the hose, in a cyclic sequence.

This is normally associated with changes in temperature and/or pressure. For complex reasons these conditions are extremely damaging to the hose liner, whatever material it is made from.

For example, hoses are sometimes used to pass steam, water, steam etc into rubber moulding presses, in order to heat the mould, then rapidly cool it before reheating in the next cycle. Hoses of all types fail rapidly in such an application and PTFE lined hoses are no exception.

Please contact Aflex Hose for further information if these conditions apply.

## • **Connecting Assemblies for Use in Applications**

The lengths of hose assemblies and their configuration in use when connected into the application must always be in accordance with the Hose Configuration information at the end of this product literature.

When being connected for use in applications, the end fittings on hose assemblies must be connected to correct mating parts in the correct way, using the correct tools, spanners, clamps, nuts and bolts etc. The connections must be sufficiently tightened to ensure that the joint is leak free but not be over tightened as this can damage the sealing surfaces.

In applications involving the transfer through the hose of expensive or dangerous fluids or gases, the hoses and connections must be pressure tested in situ before being put in to service. This should be done with some harmless media to 1½ times the maximum working pressure of the hose assembly, as stated in the product literature.

If in doubt please contact Aflex Hose for advice.

## • **Special Applications**

Aflex Hose PTFE lined hose products are not rated as suitable for use in the following, special applications:

- All Radioactive Applications involving high energy radiation, including Gamma radiation (degrades PTFE)
- All Medical Implantation Applications.
- All Aerospace Applications, except by special prior agreement, confirmed in writing.

# PHARMALINE N<sub>and</sub> X

## Quality Assurance, Certification and Approvals, and Hose Testing

### **BS EN ISO 9001:2008**

Aflex products are all manufactured in accordance with BS EN ISO 9001 Quality Management Systems independently assessed and registered by National Quality Assurance Limited (NQA).

### **EN12115**

Pharmaline N and X hose meets the relevant requirements of EN12115, but the correct specification for the electrical and electrostatic requirements is EN ISO 8031 Annex A.

### **TS16949**

Aflex Hose Ltd manufactures PTFE flexible hose for the automotive industry in accordance with TS16949 and is assessed and certified by National Quality Assurance Limited (NQA).

### **USP Class VI and ISO 10993-5, 6, 10 and 11 guidelines**

The Natural and Antistatic PTFE Hose Liners and the Platinum Cured Silicone Rubber Covers have been independently tested in accordance with USP protocols and are found to conform to the requirements of USP Class VI Chapter <88>.

Natural and Antistatic PTFE Hose Liners now also meet the more stringent USP Class VI and ISO 10993-6,10 and 11 guidelines at 121°C (250°F) with a "no reaction" classification.

Natural and Antistatic PTFE Hose Liners and Platinum Cured Silicone Rubber Covers have also been tested in accordance with USP protocols and are found to conform to the requirements of USP Class VI <87>, the L929 MEM Elution Test and are considered non-cytotoxic.

Natural and Antistatic PTFE Hose Liners have now been further tested and have passed the more stringent USP Class VI and ISO 10993-5 guidelines at 121°C (250°F).

### **USP <661> Physicochemical Test for Plastics**

Natural and Antistatic (Carbon filled) Pharmaline N and X Externally Convuluted Smoothbore PTFE hose has been tested in accordance with USP Physicochemical Test for Plastics and found to meet the criteria of the following reference: USP34, NF 29, 2011. Monograph <661> Containers, Physicochemical Test-Plastics.

### **FDA**

The Materials used to manufacture the natural PTFE Tube liner conforms to FDA 21 CFR 177.1550, and the antistatic PTFE liner conforms to FDA 21 CFR 178.3297.

### **3-A Sanitary Standards**

The PTFE used in the liner is manufactured solely from materials which meet the requirements of the 3-A Sanitary Standards.

### **BPSA leachables and extractables testing**

Aflex Hose Natural and Antistatic PTFE Hose Liner Tube has been independently tested in accordance with BPSA recommendations, and found to be satisfactory.

Copies of the Test Report are available for specific assessments to be made.

### **Pharmaceutical and Chemical Manufacturers Approvals**

Most of the major pharmaceutical and Chemical manufacturing companies in the world have audited and/or approved Aflex Hose as a Hose Supplier.

### **CE Marking (Europe only)**

Aflex has been assessed by a notified body and found to comply with the Pressure Equipment Directive 97/23/EC (European Community) Conformity Assessment Module D1, approved to CE Mark applicable hose products, accompanied by a Hose Usage Data Sheet, and a Declaration of Conformity.

### **Attestations of Conformity to ATEX Directive 94/9/EC (Potentially Explosive Atmospheres)**

Available for hose assemblies for components used in Gas Zones 1 & 2 and Dust Zones 21 & 22, when applicable.

### **Material Certification to EN10204**

Available for all the hose or hose assembly components.

### **Certificates of Conformity to BS EN ISO/IEC 17050**

Are available for all products.

### **Fuel Hose Approval to SAE J1737**

Aflex Hose PTFE hose liners have been tested and approved to SAE J1737 for Automotive Fuel Hose applications.

### **Hose Testing**

Each assembly is pressure tested to 1.5 times maximum working pressure before despatch, and pressure test certificates can be supplied.

### **Fire Resistance to BS5173 Section 103.13 Part 6.2 and 6.3**

Pharmaline N and X hose assemblies are 'Fire Resistant'. If DSI-300 is added at both ends, the assemblies are upgraded to 'Fireproof'.

# Hose Configuration & Length Calculations

## - for Bend Radius

### Hose Configuration Requirements

Hose Assemblies are usually connected at both ends in service. They may then either remain in a fixed, or static configuration or in a flexing, or dynamic configuration.

Whether static or dynamic, the First Rule concerning the configuration of the hose is that the bend radius of the hose must never be less than the Minimum Bend Radius (MBR) for the hose as listed in the relevant hose brochure.

The most common situation when this is likely to occur is when the hose is flexed at the end fitting, with stress being applied to the hose at an angle to the axis of the end fitting. Typically, this happens either because the length of the hose is too short, or because the weight of the hose plus contents creates a stress at an angle to the end fitting.

The Second Rule, therefore, if possible, is to design the configuration to ensure that any flexing in the hose takes place away from the end fittings.

#### (Dynamic) Configuration

**INCORRECT** - Hose too short

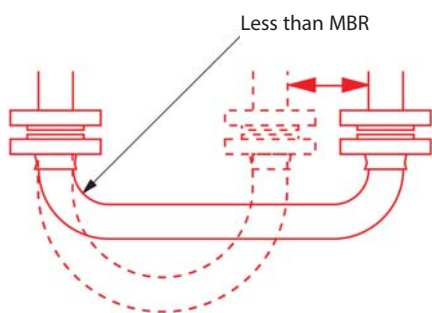

**CORRECT** - No flex at End Fittings

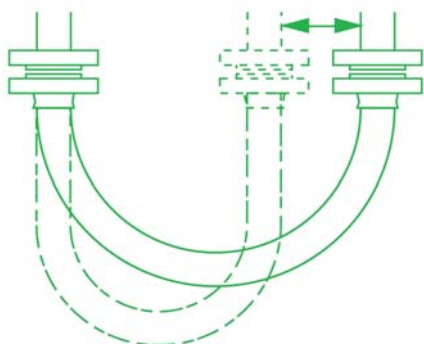

#### (Static) Configuration

**INCORRECT** - Weight of hose is at 90° to Axis of End Fittings

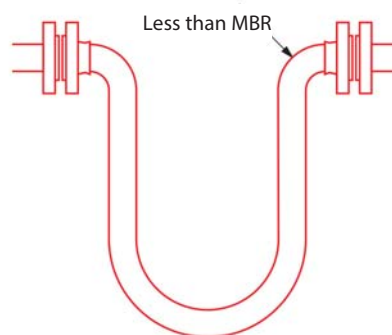

**CORRECT** - No flex at end fittings

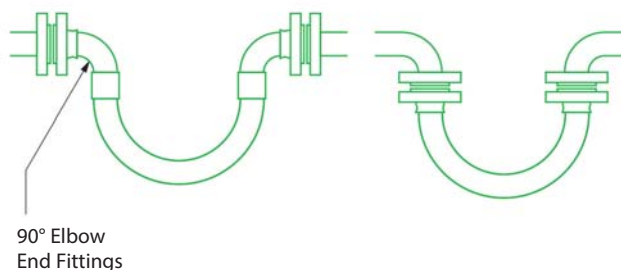

# Hose Configuration & Length Calculations

## - for Abrasion & Torque

The Third Rule is that the hose configuration should always be designed, and supported where necessary, to avoid any possibility of external abrasion. In some cases, the length, configuration and angle of the hose can be designed to avoid abrasion. In others, static or moving support frames or support wheels are required.

**INCORRECT** - Abrasion against hose

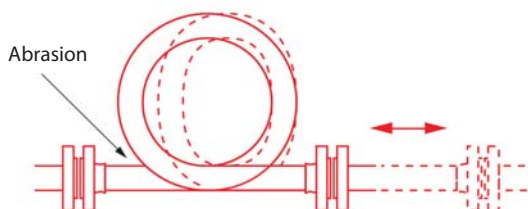

**INCORRECT** - Abrasion inside support

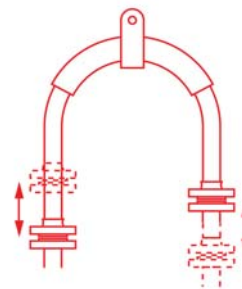

**CORRECT** - No hose abrasion

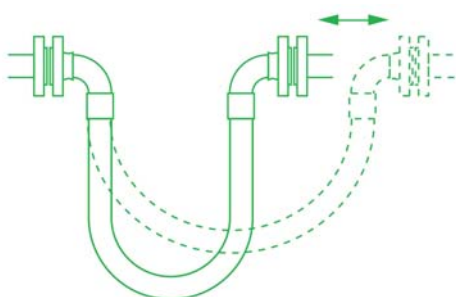

**CORRECT** - No abrasion over support

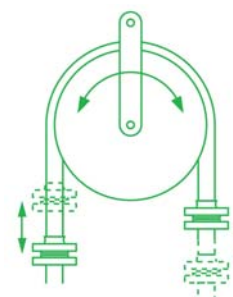

The Fourth Rule is that the hose must not be subjected to torque, either during connection, or as a result of the flexing cycle.

Torque (twist) in the hose can be applied during connection if the hose is accidentally twisted, or if the second end being connected is a screwed connection, and the hose is subjected to torque during final tightening.

In a flexing application, if any flexing cycle of the hose occurs in 3 dimensions instead of 2, then torque will also occur:

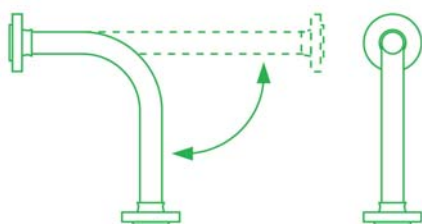

**CORRECT** - Flexing movement takes place in 2 dimensions

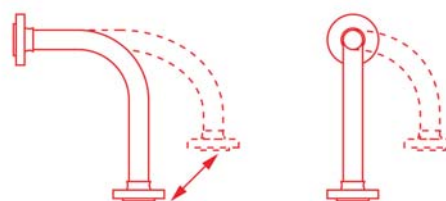
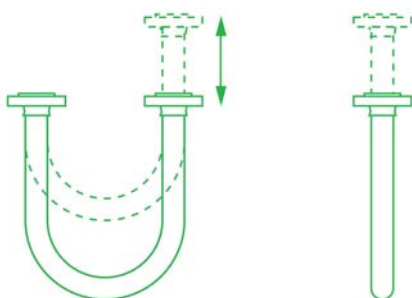

**INCORRECT** - Flexing movement takes place in 3 dimensions so torque is applied

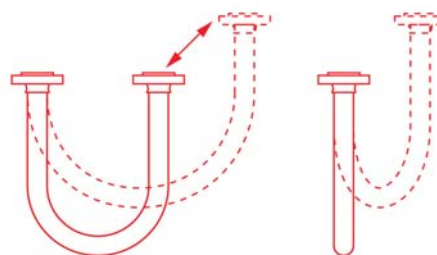

Both Corroflon and Bioflex hose have good resistance to a small level of torque, much better resistance than rubber or SS hose types, but it is still the best practice to take whatever steps are necessary to eliminate torque. If in doubt, consult Aflex Hose.



# Hose Configuration - for Length Calculation

## Calculating the Hose Length

The formula for calculating the bent section of the hose length around a radius is derived from the basic formula that the circumference of a circle =  $2\pi R$ , where  $R$  = the radius of the circle, and  $\pi$  = a constant, = 3.142.

So, if the hose goes around a  $90^\circ$  bend, which is  $1/4$  of a full circumference, and the radius of the bend is  $R$ , then the length of the hose around the bend is =  $1/4 \times 2\pi R$ . Or half way round, in a U-shape, =  $1/2 \times 2\pi R$ .

### Note :

In calculating the length of a hose assembly, the (non-flexible) length of the end fittings must be added in, also the length of any straight sections of hose, as in the following example:

### Example :

To calculate the length for a 2" bore size hose with flange end fittings, to be fitted in a  $90^\circ$  configuration with one leg 400mm long, the other 600mm long.

$$\begin{aligned} \text{Length of Bent Section (yellow)} &= 1/4 \times 2\pi R \text{ (334)} \\ &= 1/4 \times 2 \times 3.142 \times 334 = 525\text{mm} \end{aligned}$$

$$\begin{aligned} \text{Length of top, Straight Section, including the top end fitting length} \\ &= 600 - 334 = 266\text{mm} \end{aligned}$$

$$\text{Length of bottom end fitting} = 66\text{mm}$$

$$\text{Total length of Hose Assembly} = 525 + 266 + 66 = 857\text{mm}$$

### Things to consider

- A hose will normally take the longest radius available to it to go around a corner, not the MBR! Also - always remember to include the non-flexible end fitting lengths.
- In dynamic applications, remember to always calculate the lengths for the most extended configuration during the flexing cycle, not the least extended.
- If the configuration is simply too complex for calculation, then obtain a length of flexible tubing of some kind, mark on paper, or a wall, or floor, or both where the connection points will be relative to each other, scaled down if necessary, then manually run the flexible tubing between them with full radii round bends. Measure the extended length, then scale up if necessary to determine the approximate length of the hose.

If in doubt, consult Aflex Hose.

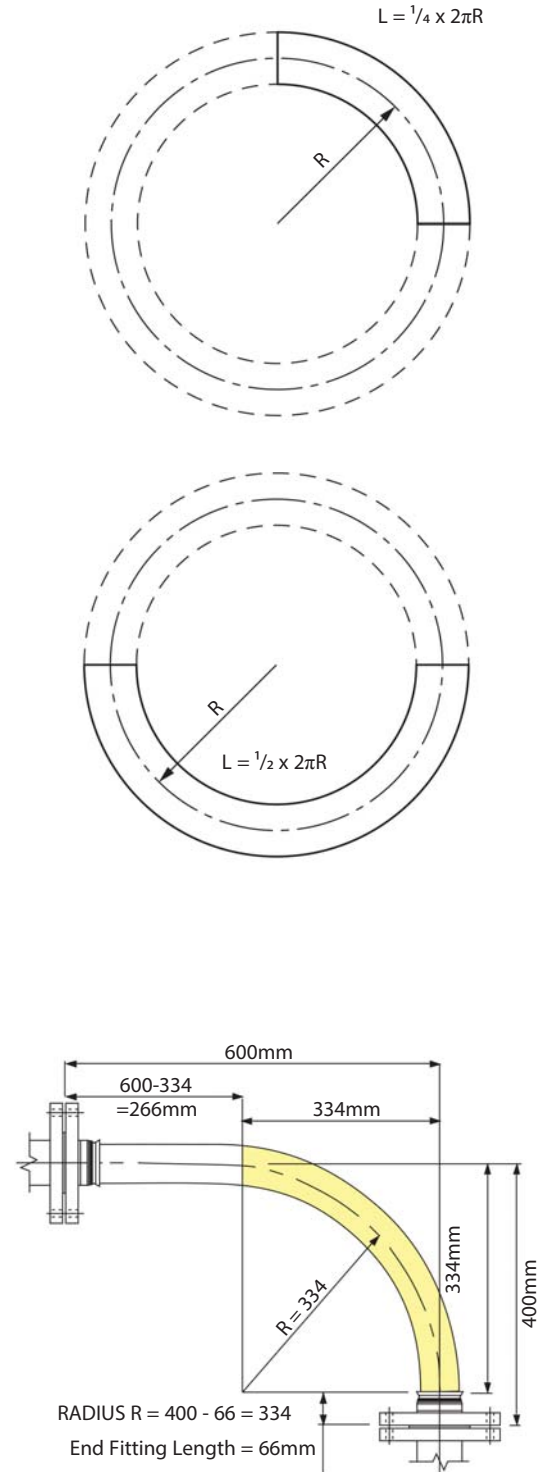

# Conditions of Sale

## Definitions

- (1) "Afex Hose" shall mean Afex Hose Limited
- (2) "Afex Hose Products" shall mean those products the Customer is purchasing from Afex Hose.
- (3) "Customer" shall mean the individual or entity that is purchasing Afex Hose Products hereunder.
- (4) "Full Product Brochure" shall mean the brochure for each specific product available at <http://www.afex-hose.com/products/>.

## General

- (5) These Conditions of Sale form the basis of the contract of sale between Afex Hose and the Customer. In the event of any conflict between the terms and conditions set forth in these Conditions of Sale and any other Customer document, these Conditions of Sale shall govern, unless otherwise agreed to in writing and authorized and signed for by a Director or General Manager of Afex Hose.
- (6) Unless otherwise agreed to in writing, delivery will be at cost from Afex Hose's facilities Brighouse, West Yorkshire, England. Title and all risks of loss or damage pass to the Customer upon delivery to the Customer or third party carrier. Delivery dates specified by Afex Hose are only Afex Hose's best estimates and Afex Hose's only responsibility will be to use reasonable commercial efforts to meet all specified delivery dates.

## Customer Responsibilities and Obligations

- (7) It is the Customer's strict responsibility to review all of the usage conditions and usage limitations given for the Afex Hose Products which are intended for use in a particular application, to ensure that the application conditions are in compliance with those usage limitations. The usage conditions and limitations are referred to in these Conditions of Sale, and are further specified in the relevant Full Product Brochure. The Customer shall consult the latest, up to date hose product information and Full Product Brochure at the time of ordering, which are only available and downloadable from the Afex Hose website at <http://www.afex-hose.com/products/>, or on request from Afex Hose. The Customer here represents and warrants that it has read and understands the applicable Full Product Brochure and the usage conditions and the usage limitations set forth therein, and has ensured their compliance with the application conditions.
- (8) If the Customer sells or assigns any Afex Hose Products to any other person or entity, the Customer shall ensure that the final end user of the Afex Hose Products is supplied with these Conditions of Sale, the applicable Full Product Brochures, the Afex Hose website address, together with notification of the requirement to review the usage conditions and limitations. The Customer shall include the terms and conditions set forth herein in its Conditions of Sale to any third party. The Customer hereby agrees and acknowledges that Afex Hose shall have no liability whatsoever for claims arising in whole or in part out of the Customer selling or assigning the Afex Hose Products to a third party that does not use the Afex Hose Products in accordance with Afex Hose's usage requirements and limitations ("Non-Conforming Use Claims"). The Customer shall indemnify and hold harmless Afex Hose, its officers, directors, employees, affiliates and representatives for any and all claims, damages, penalties and losses arising out of or related to Non-Conforming Use Claims.
- (9) The Customer agrees and acknowledges that for any intended hose application in which special conditions apply which are not defined, or not defined sufficiently in the Product Brochure, the Customer shall write to Afex Hose requesting written advice relating to any usage limitations resulting from special conditions. The Customer shall ensure the design suitability and safety of the Afex Hose Products in their intended applications, giving particular consideration to any special condition relating to, but not restricted to the chemical and electrostatic compatibility of the fluids or gases passing through, the possibility of diffusion of fluid or gases through the PTFE hose lining, the possibility of external corrosive conditions, the types and likelihood of excessive mechanical abuse, such as abrasion (internal or external), crushing, excessive flexing or vibrations, etc. and any excessive temperature and/or pressure "pulsing" conditions, or any other condition which may cause premature hose failure. The Customer shall consider, and take account of the degree of risk

involved in any hose failure, including the provision of adequate protection in the event of any risk to any persons. In applications where any type of hose failure would lead to financial losses if the hose is not replaced immediately, the Customer agrees and acknowledges that it shall be the Customer's responsibility to order and hold in stock spare hose(s) accordingly. The Customer shall advise Afex Hose in writing at the time of placing the enquiry and on any purchase order if there are any special requirements for the hose, including special cleaning, or drying, or extra testing requirements which are in addition to normal industrial standards. The Customer agrees and acknowledges that Afex Hose, its officers, directors, employees, affiliates and representatives shall not be held liable for any claims or obligations arising out of the Customer's failure to fulfill any or all of its responsibilities set forth in this Section 9.

- (10) If the Customer has any doubts concerning these or any other usage conditions and limitation or safety parameters, the Customer shall consult Afex Hose at the number and address in the Notice Provisions below and request a written response to any queries.

## Hose Service Life; 24 Month Warranty

- (11) It is not possible to guarantee a minimum service life for any of the Afex Hose Products which can be applicable for every type of application. As such, Customer acknowledges that, except as provided below in Sections 12, 13 and 14 Afex Hose is not guaranteeing a minimum service life of any of the Afex Hose Products.
- (12) Service life predictions or guarantees can only be given in cases where all the relevant information concerning the application is given in writing to Afex Hose, and Afex Hose subsequently replies in writing with the service life prediction prior to the order being placed.
- (13) If such a written undertaking is not sought and given, Afex Hose shall not be held liable for any Afex Hose Product failure which the Customer considers to be premature, excepting failures which are due to faulty materials or manufacturing defects which occur within 24 months or 12 months, as applicable, of supply as provided in Section 14 below.
- (14) Afex Hose warrants its Afex Hose Products to be free from faulty materials or manufacturing defects from the date of the delivery, for 24 months; provided, however, that all Hose Assemblies which are "ETH" (Electrical Trace Heated) Grade are only warranted for 12 months.
- (15) AFEX HOSE MAKES NO WARRANTY OF ANY KIND WHATSOEVER, EXPRESS OR IMPLIED OTHER THAN AS SPECIFICALLY STATED HEREIN, AND THERE ARE NO WARRANTIES OF MERCHANTABILITY AND/OR FITNESS FOR A PARTICULAR PURPOSE WHICH EXCEED THE OBLIGATIONS AND WARRANTIES SPECIFICALLY STATED HEREIN.

## Product Failure

- (16) In the event of a product failure during the applicable warranty period set forth in Section 14, the Customer shall provide Afex Hose with written notification within forty-eight (48) hours of discovering the fault. Afex Hose requires that the Afex Hose Products not be cut up or tampered with, but should be decontaminated and returned to Afex Hose, plus a decontamination certificate, for examination and analysis of the fault. The Customer should also provide full details in writing of the application conditions under which the hose failed, including Pressure, Vacuum, Temperature, Flexing and any cycling of any of these, also the fluids, gases and any cleaning products passed through the hose, and the total time that the hose has been in service also the original order number and the Serial Number for the hose. The Customer may send its own witness to the examination if required. Afex Hose will provide a Non-Conformance Report to the Customer. The Customer shall bear the cost of returning the Afex Hose Products that have failed; provided, however, as set forth in Section 17 below, Afex Hose shall reimburse the Customer for any shipping costs if it is determined that the failure is covered by the warranty set forth in Section 14.

# Conditions of Sale continued

- (17) If Aflex Hose determines that the faulty materials or a manufacturing defect in the hose is responsible for the hose failure, Aflex Hose's maximum liability shall be the invoice value of the failed hose itself, or the invoice value of the whole customer order as determined by Aflex Hose in its sole discretion, along with any reasonable costs for removal and replacement of the hose, and costs for packing and despatching the failed hose back to Aflex Hose.

## Untested Hose for Self Assembly by Customers

- (18) Aflex Hose sometimes supplies "loose" hose, without end fittings attached to a Self Assembly Customer, who will then cut the hose to length and attach end fittings to make up Hose Assemblies for their own use, or for sale to their own customers.
- (19) Unless the Customer requests, and Aflex Hose confirms that the 'loose' hose is pressure tested before supply, such testing is not normally applied by Aflex Hose, because this testing requirement is otherwise satisfied by the Self Assembly Customer during his own testing of the finished Hose Assemblies made up using the "loose" hose. Self Assembly Customers agree and acknowledge that they are solely responsible for carrying out hydrostatic pressure testing of 100% of such assemblies to 1 1/2 times the Maximum Working Pressure (MWP) of the hose assembly as specified in the relevant Full Product Brochure before supply for end use, to validate both the hose and the end fitting attachment.
- (20) When pressure testing braided hoses with a plastic or rubber outer cover, the cover will mask any signs of leakage for a time. The Customer agrees and acknowledges that after the hydrostatic pressure test, it is required to test each covered hose assembly with an internal helium gas pressure of 30 Bar (450 psi) for hose sizes up to 1" and 15 Bar (225 psi) for hose sizes above 1", with the hose assembly immersed in water to enable leak detection by gas bubbles, for a minimum test period of 5 minutes.
- (21) The "Self Assembly" Customer agrees and acknowledges that it shall determine and approve the Design Suitability of the hose assemblies for their intended use before supply and that, except as set forth in Section 22, it shall indemnify and hold Aflex Hose harmless from any Claims and Losses arising from Design Suitability for a Self Assembly Customer. This includes proceeding in accordance with Section (7) and Section (8) above.
- (22) Aflex Hose's liability is limited to Aflex Hose Products which are assembled by approved Self Assembly Customers if all the hose and fitting components were supplied by Aflex Hose or approved for use by Aflex Hose in writing, and they were assembled and tested in accordance with Aflex Hose's current Manufacturing and Testing Instructions, available to approved Self Assemblers in an I-Bay on the Aflex Hose website.

## Untested Hose Assemblies

- (23) Aflex Hose is sometimes requested by Customers to attach non-standard end fittings to hose assemblies which they, supply, and in some cases it is not possible to connect these fittings to the Aflex Hose pressure test system. In such cases a "concession not to test" is obtained from the Customer, and a label is attached to the hose assembly, warning that it requires pressure testing before use. The Customer agrees and acknowledges that Aflex Hose shall have no liability whatsoever if the Customer does not comply with the warning that requires pressure testing before use.

## Force Majeure

- (24) Aflex Hose shall not be liable for any delay in delivery, failure to deliver or default in performing in accordance with any Customer's order if the delay or default is due to: (a) fires, floods, strikes, or other labor disputes, accidents to Aflex Hose's production facilities, acts of sabotage, riots, natural disasters, difficulties procuring materials, shortages of raw materials, interference by civil or military authorities, whether legal or de facto, governmental restrictions, including but not limited to failure to obtain export licenses, delays in transportation or lack of transportation facilities, restrictions imposed by federal, state or other governmental legislation or, rules or regulations thereof, including a force majeure event occurring in respect to one of Aflex Hose's suppliers; or (b) any other cause beyond Aflex Hose's control.

## Governing Law; Jurisdiction

- (25) These Conditions of Sale and all rights, duties and obligations hereunder, including any and all other Customer agreements and orders shall be governed by and subject to English Law.
- (26) The Customer acknowledges and agrees that any disputes arising out of or related in any way to this Agreement, including a breach of this Agreement, shall be brought exclusively in the courts of England, United Kingdom. Furthermore, Customer knowingly, voluntarily and irrevocably (a) consents to the exclusive jurisdiction of these courts, (b) waives any immunity or objection, including any objection to personal jurisdiction or the laying of venue or based on the grounds of forum non conveniens, which it may have from or to the bringing of the dispute in such jurisdiction, (c) waives any personal service of any summons, complaint or other process that may be made by any other means permitted by England, United Kingdom, (d) waives any right to trial by jury, (e) agrees that any such dispute will be decided by court trial without a jury, (f) understands that it is giving up valuable legal rights under this Section 26, including the right to trial by jury, and that it voluntarily and knowingly waives those rights.

## Limitations of Liability

- (27) Aflex Hose Products have not been designed or tested for use in aerospace, medical implantation or radioactive applications, and such use is therefore strictly prohibited unless written approval from Aflex Hose has been given. Customer agrees and acknowledges that it is aware of the limitations set forth in this Section 26 and hereby agrees that Aflex Hose shall not have any liability whatsoever in the event Customer uses Aflex Hose Products for aerospace, medical implantation or radioactive applications. Customer agrees to indemnify Aflex Hose, its officers, directors, employees, affiliates and representatives for any and all Claims and Losses arising out of Customer's use of the Aflex Hose Products for aerospace, medical implantation or radioactive applications.
- (28) Aflex Hose will not accept liability for any failures of the Aflex Hose Products which are caused by Customers failing to perform their Responsibilities as specified in these Conditions of Sale.
- (29) NOTWITHSTANDING ANYTHING TO THE CONTRARY HEREIN, IN NO EVENT SHALL AFLEX HOSE BE LIABLE FOR ANY SPECIAL, INDIRECT, INCIDENTAL, CONSEQUENTIAL, EXEMPLARY, OR PUNITIVE DAMAGES, LOSS OF PROFITS OR REVENUE, LOSS OF PROCESS PRODUCTS, DAMAGE TO EQUIPMENT, DOWNTIME COSTS, OR LOSS OF USE EVEN IF INFORMED OF THE POSSIBILITY OF SUCH DAMAGES. TO THE EXTENT PERMITTED BY APPLICABLE LAW, THESE EXCLUSIONS AND LIMITATIONS WILL APPLY REGARDLESS OF WHETHER LIABILITY ARISES FROM FAILURE OF THE PRODUCT(S), BREACH OF CONTRACT, FAILURE TO DELIVER ON TIME, WARRANTY, TORT (INCLUDING, BUT NOT LIMITED TO, NEGLIGENCE), BY OPERATION OF LAW, OR OTHERWISE.

## Completion of Bulk Hose Orders

- (30) Due to the nature of the production of PTFE hose, Aflex Hose reserves the right to call an order complete in the following situations. If a product is a standard Aflex product (as listed in Aflex product brochures) a figure of +10% of original order quantity can be supplied. If the product is a non-standard product and outside the Aflex standard product range the figure of +/- 10% of the original order quantity can be supplied. Goods supplied within these parameters would render the order complete.

## Notice Provisions

- (31) Any written notice required to be provided to Aflex Hose shall be sent to the following address: Aflex Hose Limited, Spring Bank Industrial Estate, Watson Mill Lane, Sowerby Bridge, Halifax, West Yorkshire, HX6 3BW.

## Exclusion of CISG

- (32) The United Nations Convention on Contracts for the International Sale of Goods shall not apply to these Conditions of Sale and any and all other Customer documents.



UK PHAN/PHAX/06.10.15 Rev 6

## UK

Spring Bank Industrial Estate  
Watson Mill Lane  
Sowerby Bridge  
Halifax  
West Yorkshire, HX6 3BW  
Tel: +44 (0) 1422 317200  
Fax: +44 (0) 1422 836000

## USA

6111 Kellers Church Road  
Unit B  
Pipersville,  
Pa 18947  
Tel: 215 - 766 - 1455  
Fax: 215 - 766 - 1688

[www.aflex-hose.com](http://www.aflex-hose.com)

